

INDUSTRIAL CRANES

EXPERIENCE WHERE YOU NEED IT

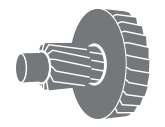

CORE OF
LIFTINGCORPORATE
RESPONSIBILITY

WE STAND BEHIND OUR CRANES

We have more than 80 years of experience manufacturing lifting equipment from hoists to process cranes, lifting loads from 50 kg to 500 tons. We offer an extensive selection of industrial lifting equipment using the latest technology, and supported by a comprehensive service offering. With Konecranes, you are making a long-term investment that will help you achieve improved safety and productivity for many years to come.

Decades of working closely with customers across many different industries has given us the knowledge necessary to help you choose the right equipment for your environment and application. We understand that there is no “one size fits all” when it comes to lifting.

From the moment we go to the design drawing board, every product we make represents quality. Each core component is engineered specifically for lifting, with safety as the highest priority and improved productivity the ultimate goal. Our strict quality control, maintained by extensive testing throughout every phase of production, means we can vouch for our products and proudly stand behind them.



**CAN CRANES
BE BUILT WITH
GENERAL PURPOSE
COMPONENTS?**

[READ MORE](#)

**IS CONTINUOUS
QUALITY TESTING
IMPORTANT?**

[READ MORE](#)

**IS SAFETY
MORE THAN
A HELMET?**

[READ MORE](#)

**READY FOR
A RELIABLE,
LONG-TERM
INVESTMENT?**

[READ MORE](#)

READ MORE ABOUT LIFTING AROUND THE GLOBE



LIFTING AROUND THE GLOBE

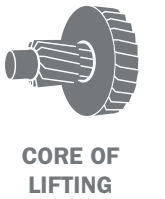

Konecranes is one of the world’s largest suppliers of industrial cranes and has the most extensive service network in the industry. We are global yet local with manufacturing in more than 20 countries, and more than 600 service locations in nearly 50 countries. We have the experience, scale and know-how to provide reliable lifting equipment that lasts.

We believe that corporate responsibility is an essential part of sustainable growth. We respect our personnel, the environment, and the societies in which we operate. Continuous improvement directs everything we do. Our commitment can be seen in our values, policies, and Code of Conduct.

From the moment we start the design process, we always consider usability, eco-efficiency and safety as guiding principles across the full product life cycle of every crane. Operational efficiency, including minimizing the use of energy, raw materials and chemicals, is essential to Konecranes.

The environmental impact of our cranes is always taken into account at every stage of their life cycle, from the production of raw materials and components, to manufacturing, use and maintenance, disposal of the product and the transport required.

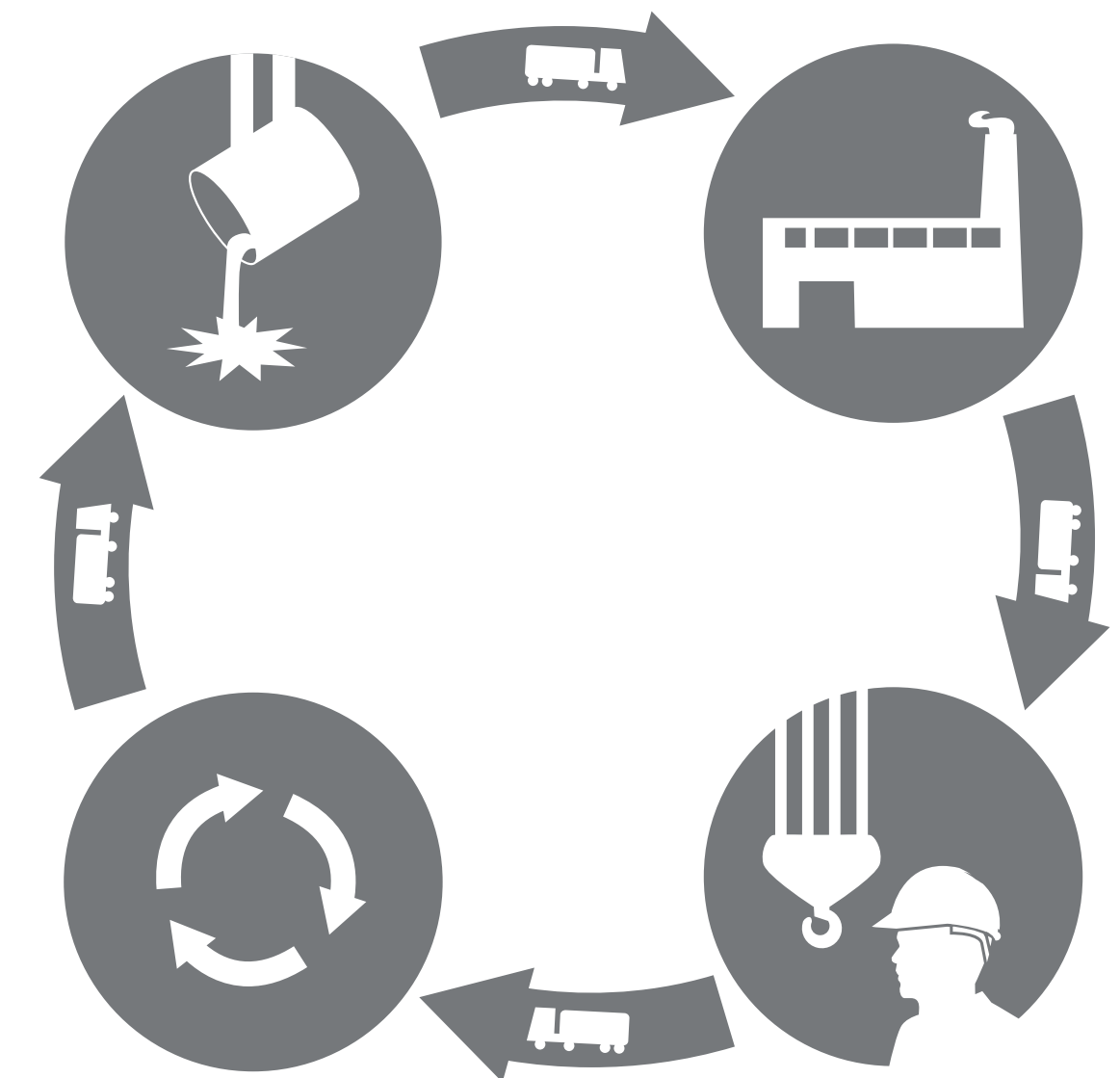

ENVIRONMENTALLY CONSCIOUS DESIGN



MANUFACTURING AND DELIVERY



ECO-EFFICIENT PRODUCT FEATURES



MAINTENANCE AND MODERNIZATION

THE CORE OF LIFTING IN INDUSTRIAL CRANES

Our products are designed around key components that we design and manufacture in-house: the Konecranes gears, motors and controls. The key component package is integrated to work in unison, as the core of the crane. We don't just design every component, we design the interaction between them specifically for crane use. This in-house approach allows us to satisfy customer-specific needs with the benefits of high-volume manufacturing.

THIS IS THE CORE OF LIFTING IN ACTION

[WATCH THE VIDEO ▶](#)

GEARS

- ⊕ A longer lifetime for your crane
- ⊕ The Konecranes promise of quality
- ⊕ Maximizing safety with good design
- ⊕ Technical details: helical gear reducers

MOTORS

- ⊕ Motors meant for cranes
- ⊕ The right motor for the right job
- ⊕ Quality gives less downtime and better safety
- ⊕ We comply with all the international standards

CONTROLS

- ⊕ Safety in every detail
- ⊕ Well-designed controls mean a safer crane
- ⊕ Excellent software makes an excellent crane
- ⊕ Smart Features for more flexible lifting
- ⊕ It gets even easier with automation
- ⊕ Motor controls just for cranes
- ⊕ Collecting, reading and understanding data



CORE OF
LIFTING



CORPORATE
RESPONSIBILITY

WORKSTATION LIFTING SYSTEMS

Workstation lifting equipment must be adaptable to changing processes and operating environments. In our range of workstation lifting systems you will find a product suitable for your workstation set-up, offering material handling from precise maneuvering to demanding repetitive use. The goal is safe, very efficient lifting of all kinds of loads.

CLX AND SLX ELECTRIC CHAIN HOISTS



ATB AIRBALANCERS



XA ALUMINIUM WORKSTATION CRANES



XM STEEL WORKSTATION CRANES



JIB CRANES



MANUAL PRODUCTS



READ MORE ABOUT EACH WLS PRODUCT





WORKSTATION LIFTING SYSTEMS OFFERING

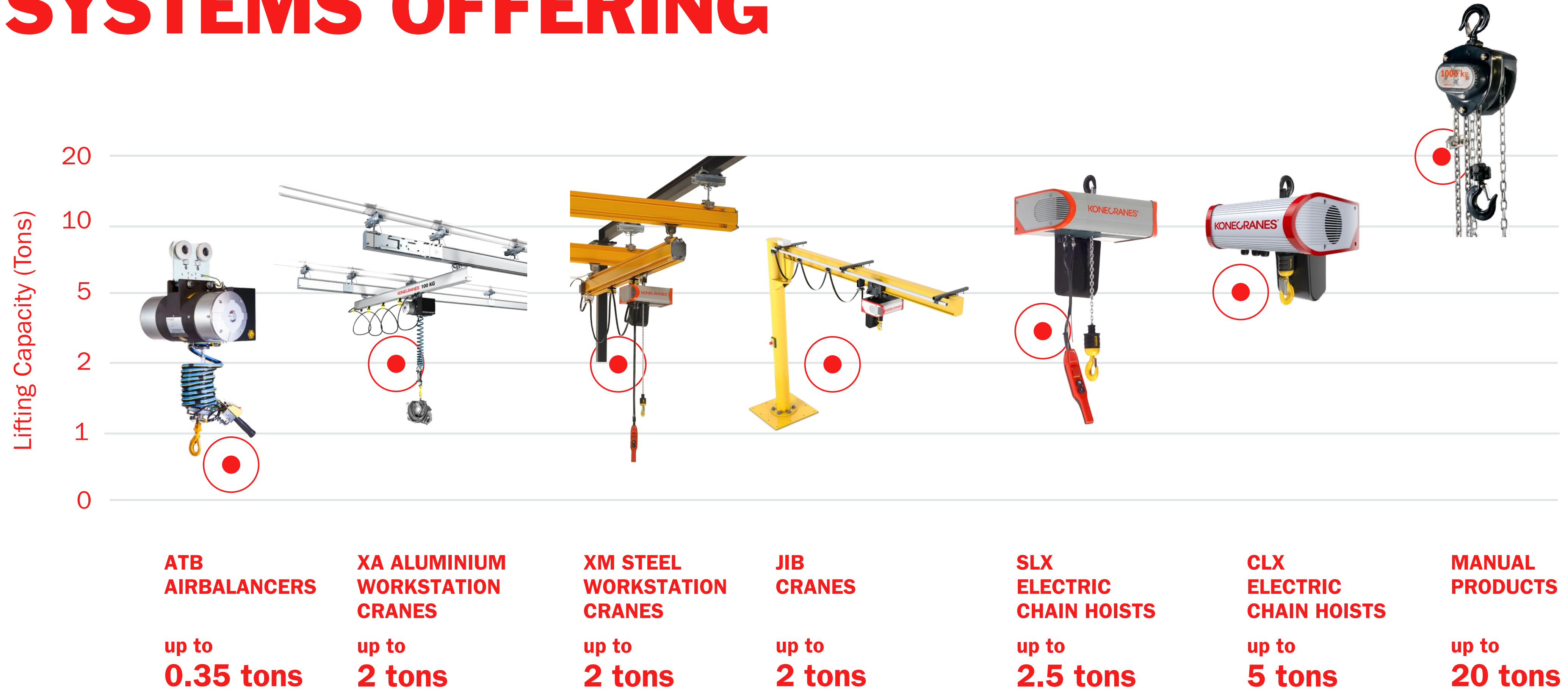

READ MORE ABOUT EACH WLS PRODUCT



CLX AND SLX ELECTRIC CHAIN HOISTS

IDEAL FOR VARIOUS WORKSTATIONS

Konecranes electric chain hoists are designed for adaptability and durability in lifting. The CLX electric chain hoist offers up to 5,000 kg of lifting capacity and the SLX up to 2,500 kg. Compact headroom, hook suspension and a range of other features make these hoists very adaptable to your specific workstation needs.

APPLICATIONS

Versatility and adaptability make Konecranes electric chain hoists an ideal fit for many lifting applications and busy workstations.

[SEE TECH SPECS AND KEY OPTIONS](#)

- **IMPROVED SAFETY WITH INTEGRATED HOIST LIMIT SWITCH, SECURING BRAKE AND HOOK BLOCK**
- **EASY SERVICEABILITY AND SIMPLE MAINTENANCE ACCESS**
- **DURABLE AND EXTREMELY VERSATILE**
- **INVERTED-CONTROLLED SLX HOIST HAS PROGRAMMABLE LIMIT SWITCHES, SHOCK LOAD ABSORPTION AND EXTENDED SPEED RANGE**



[SEE THE CLX
AND SLX IN ACTION](#)



[SEE MORE WLS PRODUCTS](#)



ATB AIRBALANCERS

SAFER, EASIER LIFTING WITH LOAD WEIGHT COMPENSATION

The ATB AirBalancer has a lifting capacity of up to 350 kg. It uses a floating load unit, harnessing air pressure as the power source. Load weight compensation allows loads of varying weights to be lifted at the same speed, giving predictable up/down control. The ATB is also available with an automatic load balancing feature, which makes it possible to lift a unit by hand in zero gravity mode.

APPLICATIONS

The ATB AirBalancer is ideal for fast pick-and-place operations and accurate load positioning. It's a great tool for assembling, packing and maneuvering items by hand.

[SEE TECH SPECS AND KEY OPTIONS](#)

- **LOAD FEELS ALMOST WEIGHTLESS**
- **SAFE AND EASY TO USE**
- **HIGHLY CONFIGURABLE**
- **SHORTER CYCLE TIMES WITH ADJUSTABLE SPEEDS**
- **EXTREMELY HEAVY-DUTY WITH 100% DUTY CYCLE**
- **CLEAN AND QUIET OPERATION**
- **THREE-DIMENSIONAL LOAD MOVEMENT WITHOUT BUTTONS OR HANDLES**

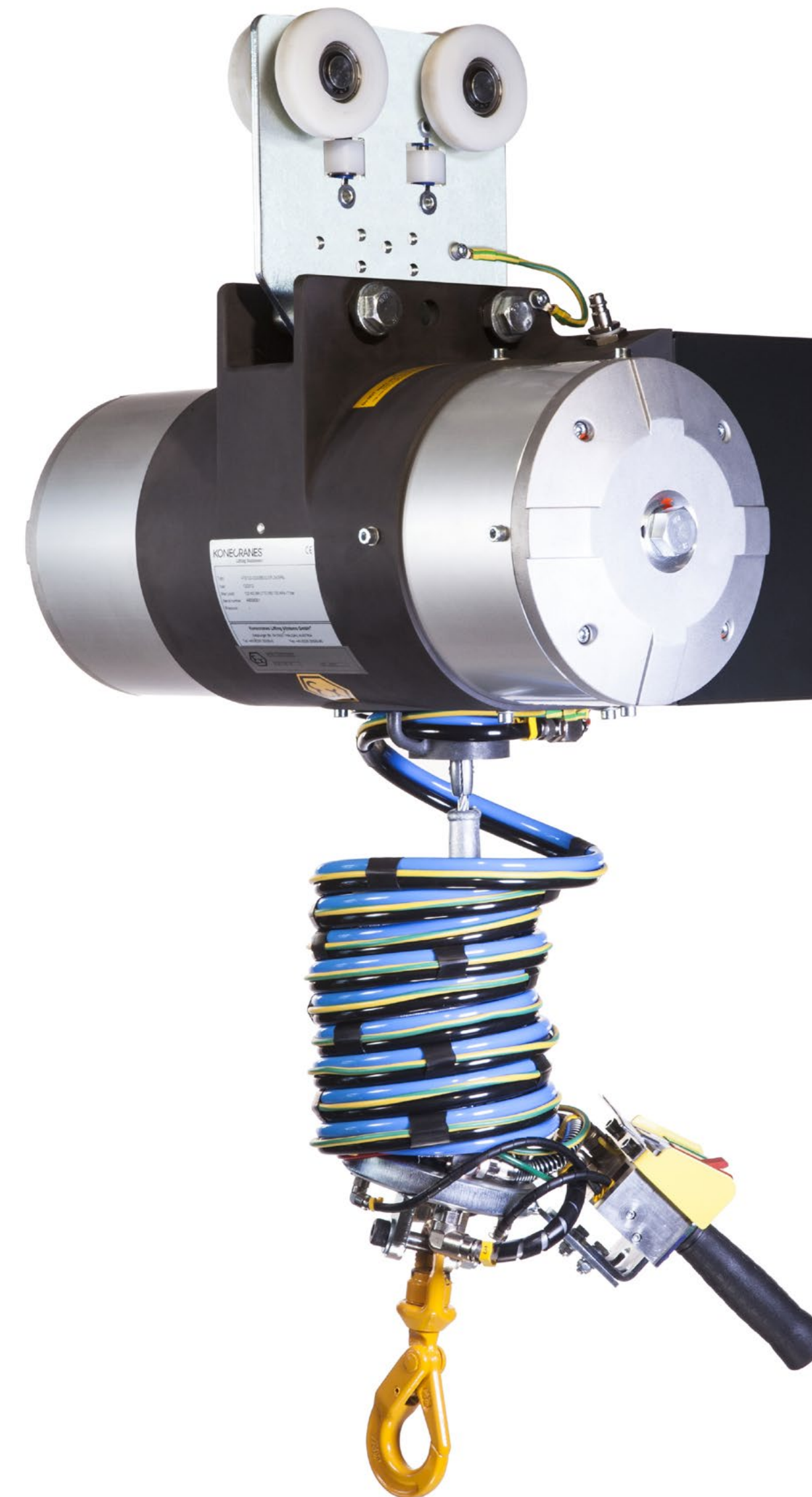

Also available as EX.



[SEE THE AIRBALANCER IN ACTION](#)



[SEE MORE WLS PRODUCTS](#)



XA ALUMINIUM WORKSTATION CRANES

EXTREMELY LIGHT, EXTREMELY DURABLE

XA handles loads up to 2,000 kg across a wide variety of rail types, and is a cost-efficient solution for various work areas. Lighter than steel by 50%, the crane gives less rolling resistance compared to equivalent steel systems. It is extremely light, and provides easy and smooth traveling movement with low hand force.

APPLICATIONS

The XA is easily adaptable for multiple processes, and its anodized aluminum surface makes it resistant to dusty or corrosive environments.

[SEE TECH SPECS AND KEY OPTIONS](#)

- **SAFE, SMOOTH AND ERGONOMIC OPERATION**
- **SHORT INSTALLATION TIME**
- **EASY EXTENSIONS WITH PROFILES WITH BOLT CONNECTIONS**
- **MINIMAL MAINTENANCE**
- **LIFETIME PROTECTION AGAINST CORROSION**

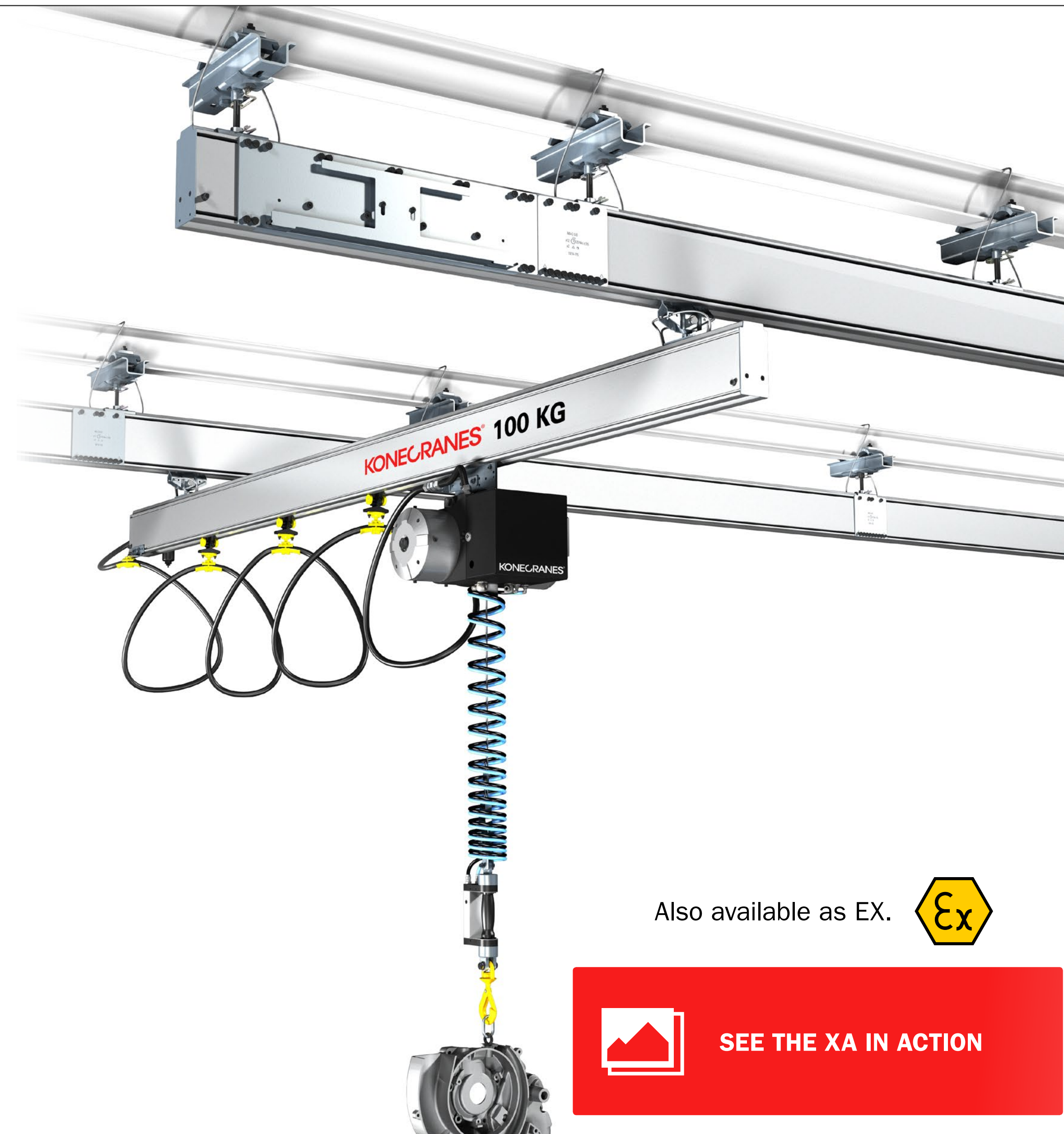

Also available as EX.



[SEE THE XA IN ACTION](#)



[SEE MORE WLS PRODUCTS](#)



XM STEEL WORKSTATION CRANES

STRONG AND ROBUST

The XM has a lifting capacity up to 2,000 kg and smooth traveling, with a high-quality finish and unique quality profile. Its strong steel profiles allow long suspension distances and long span lengths for extra adaptability. A maximized working area below the crane helps to increase productivity and makes the crane easier to operate.

APPLICATIONS

Suitable for various tasks and facilities, the XM is especially compatible with the CLX and SLX electric chain hoists.

[SEE TECH SPECS AND KEY OPTIONS](#)

- **LONGER LIFETIME AND REDUCED MAINTENANCE COSTS WITH DUST AND DIRT PROTECTION**
- **WELD-FREE MODULAR SYSTEM**
- **EASY TO INSTALL, MODIFY AND EXTEND**
- **LONG SUSPENSION DISTANCES MINIMIZE STEEL STRUCTURES AND REDUCE OVERALL COSTS**



[SEE THE XM IN ACTION](#)



[SEE MORE WLS PRODUCTS](#)



JIB CRANES

FOR A CHANGING WORK ENVIRONMENT

Jib cranes are a cost-effective method of handling loads of up to 2,000 kg. Our standard wall-mounted jib cranes can rotate up to 180°, and pillar jibs can move through 270°. Jib cranes are highly adaptable, a good fit in various workshops and industries.

APPLICATIONS

Konecranes jib cranes are very adaptable, with several mounting methods, including both floor and wall installation.

[SEE TECH SPECS AND KEY OPTIONS](#)

- **HIGH EFFICIENCY DUE TO LOW WEIGHT, UNIQUE SHAPE AND LOW FRICTION WHEELS**
- **EASY INSTALLATION AND RELOCATION REDUCES DOWNTIME AND INSTALLATION COSTS**
- **HIGHER LIFTING CAPACITY OR FULL 360° ROTATION AS OPTIONS**
- **ADJUSTABLE ROTATION STOP WITH 10° INCREMENTS AND A 3-POSITION LOCK (-90°, 0°, +90°) AS OPTIONS**



Also available as EX.



[SEE JIB CRANES IN ACTION](#)



[SEE MORE WLS PRODUCTS](#)



MANUAL PRODUCTS

SAFE AND RELIABLE MANUAL LIFTING

Our manual products are an excellent choice for any environment, even in heavy-duty operations, where electricity is impractical or not available. They can also be easily installed to work with your existing equipment.

Konecranes manual products lift from 250 kg to 20,000 kg. They don't require electrical power, so they're a good choice when you don't need them every day. The compact design makes them lightweight, which makes loads easier and safer to handle.

APPLICATIONS

Our manual hand chain blocks and manual lever pullers are your choice for construction, maintenance and service work.

[SEE TECH SPECS AND KEY OPTIONS](#)

- **AN ECONOMICAL SOLUTION WITH A WIDE LOAD RANGE**
- **IDEAL WHEN ELECTRICITY IS NOT AVAILABLE OR PRACTICAL**
- **VARIOUS FEATURES TO ENHANCE WORK ERGONOMICS**



Also available as EX.



[SEE MANUAL PRODUCTS IN ACTION](#)

OVERHEAD CRANES

The Konecranes range of cover almost every lifting application imaginable, from high-quality, basic cranes up to the most advanced and specialized lifting technology available on the market today. If you can't find a suitable off-the-shelf option, we can provide tailor-made equipment that will meet your needs.

CLX CHAIN HOIST CRANES



UNITON CRANES



CXT CRANES



SMARTON CRANES



TAILORED CRANES



CORE OF LIFTING



CORPORATE RESPONSIBILITY



READ MORE ABOUT EACH OVERHEAD CRANE



OVERHEAD CRANES OFFERING

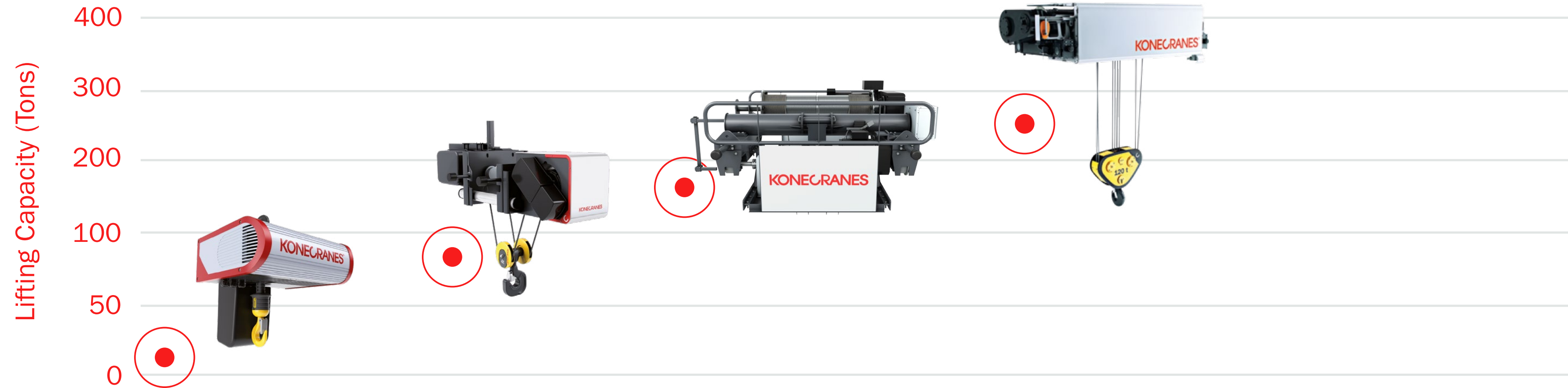
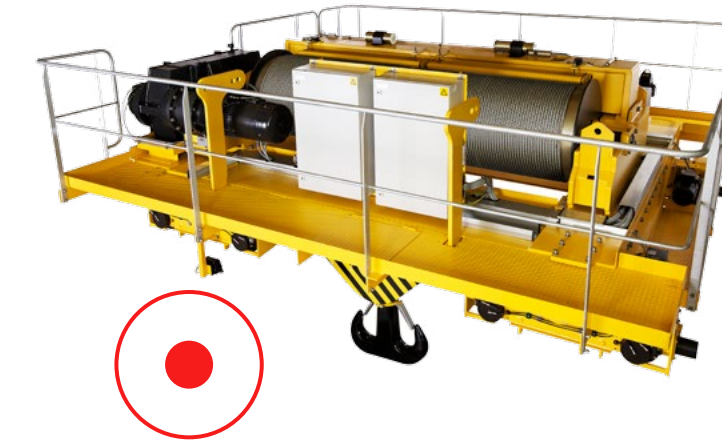

**CLX CHAIN
HOIST CRANES**

up to
5 tons

**CXT® WIRE ROPE
HOIST CRANES**

up to
80 tons

**UNITON®
CRANES**

up to
160 tons
(320 tons with
two trolleys)

**SMARTON®
CRANES**

up to
250 tons
(500 tons with
two trolleys)

**TAILORED
CRANES**



READ MORE ABOUT EACH OVERHEAD CRANE PRODUCT



CLX CHAIN HOIST CRANES

FOR A CHANGING WORK ENVIRONMENT

With a lifting capacity up to five tons, our chain hoist crane is suitable for many different industries, such as general manufacturing and maintenance. Strong design and smooth controls make the CLX chain hoist crane a strong link in your manufacturing process. It represents our latest technology and structural design, giving you the best in ergonomics, durability and reliability.

APPLICATIONS

The crane can be configured for various industrial settings and facilities.

[SEE TECH SPECS AND KEY OPTIONS](#)

- **STEPLESS SPEED CONTROL WITH OPTIONAL HOISTING INVERTER**
- **LOAD CONTROL FOR IMPROVED SAFETY AND PRECISION**
- **LONG-LASTING STEEL STRUCTURE**
- **COMPACT DIMENSIONS**
- **SIMPLE TO MAINTAIN WITH EASY SERVICE ACCESS**



[SEE CLX CHAIN HOIST CRANES IN ACTION](#)



[SEE MORE OVERHEAD CRANE PRODUCTS](#)



CXT® CRANES

RAISE YOUR EVERYDAY LIFTING TO A HIGHER LEVEL

Our range of CXT wire rope hoist cranes are ideal in nearly any industrial setting where you need a lifting capacity of up to 80 tons. The CXT is the industry leader in medium to heavy-lifting indoor cranes. Available in a range of models from basic to advanced, the CXT's adaptability is one of its greatest strengths. With specially-tailored girder designs and trolley configurations, the strong and reliable CXT can fit into all building types.

APPLICATIONS

The CXT is adaptable to nearly any industrial setting and building.

[SEE TECH SPECS AND KEY OPTIONS](#)

[SMART FEATURES AVAILABLE FOR CXT CRANES, READ MORE.](#)



- **MAXIMIZES THE USE OF SPACE UNDER THE CRANE**
- **EXCELLENT HOOK APPROACHES**
- **LARGE VARIETY OF FEATURES**
- **BETTER SAFETY THROUGH HIGH-PERFORMANCE BRAKES, DURABLE WIRE ROPES AND REMOTE OPERATION**



The most frequently-requested CXT cranes are also available as predesigned packages.

CXT UNO, a basic crane with a 12.5 ton capacity, designed for everyday use

CXT NEO, lifting up to 12.5 tons and including advanced features such as radio and inverter hoisting with adaptive speed range



[SEE CXT CRANES IN ACTION](#)



[SEE MORE OVERHEAD CRANE PRODUCTS](#)



UNITON® CRANES

NOT JUST A CRANE

UNITON is a crane that offers you the performance you need from standard to advanced. UNITON offers a load and duty class range that comprehensively covers the requirements of customers in a wide range of industry applications. It can lift from 6.3 to 160 tons and is designed for process duty.

APPLICATIONS

UNITON is especially well adapted for heavy process duty applications such as steel warehousing, automotive production and other metal industry applications.

[SEE TECH SPECS AND KEY OPTIONS](#)

[SMART FEATURES AVAILABLE FOR UNITON CRANES, READ MORE.](#)



- **DESIGNED AND BUILT FOR THE SPECIFIC CONDITIONS OF YOUR FACILITY**
- **EASILY TAILORED WITH MULTIPLE CONFIGURATIONS**
- **EASY MAINTENANCE DUE TO A SIMPLE DESIGN**



[SEE THE UNITON CRANES IN ACTION](#)



[SEE MORE OVERHEAD CRANE PRODUCTS](#)



SMARTON® CRANES

FOR ASSEMBLY AND SERVICE DUTY

SMARTON is an open-winch type overhead crane used by many of the world's leading industrial companies for heavy load lifting. It was developed for demanding assembly and maintenance use, offering you the right mix of mechanical and electrical excellence in a compact size, as well as software-based intelligence and service support. SMARTON lifts from 6.3 to 250 tons with a single hoisting trolley.

APPLICATIONS

SMARTON is the right choice for customers requiring assembly or maintenance cranes with high lifting capacities. A great strength of SMARTON is the compact size. Thanks to its compact approach dimensions, space in the factory layout can be used more efficiently.

[SEE TECH SPECS AND KEY OPTIONS](#)

[SMART FEATURES AVAILABLE FOR SMARTON CRANES, READ MORE.](#)



- **SAFE AND EFFICIENT OPERATION**
- **MOST ADVANCED CRANE SOFTWARE AVAILABLE**
- **COMPACT TROLLEY SIZE AND MINIMIZED APPROACH DIMENSIONS THANKS TO INTEGRATED STRUCTURE**



[SEE THE SMARTON CRANES IN ACTION](#)



[SEE MORE OVERHEAD CRANE PRODUCTS](#)



TAILORED CRANES

INDIVIDUALLY DESIGNED LIFTING EQUIPMENT

Our standard offering, with its wide range of options, is often enough even for demanding applications. But we can also provide a tailor-made crane for your process. With lifting capacities of up to several hundred tons, our tailored cranes can be optimized to your precise lifting needs. Our tailored cranes are often built from our standard cranes in innovative ways. We can also design new crane elements as needed.

APPLICATIONS

We offer ready-made solutions for a number of industries, but we also develop tailored cranes using our field-proven, heavy-duty components. We work closely with the customer to customize each crane case-by-case, ensuring that every crane is the right one for the work it has to do.

- CAN BE TAILORED TO FIT MOST ENVIRONMENTAL AND PROCESS REQUIREMENTS
- HEAT AND CORROSION PROTECTION FOR DEMANDING ENVIRONMENTAL CONDITIONS

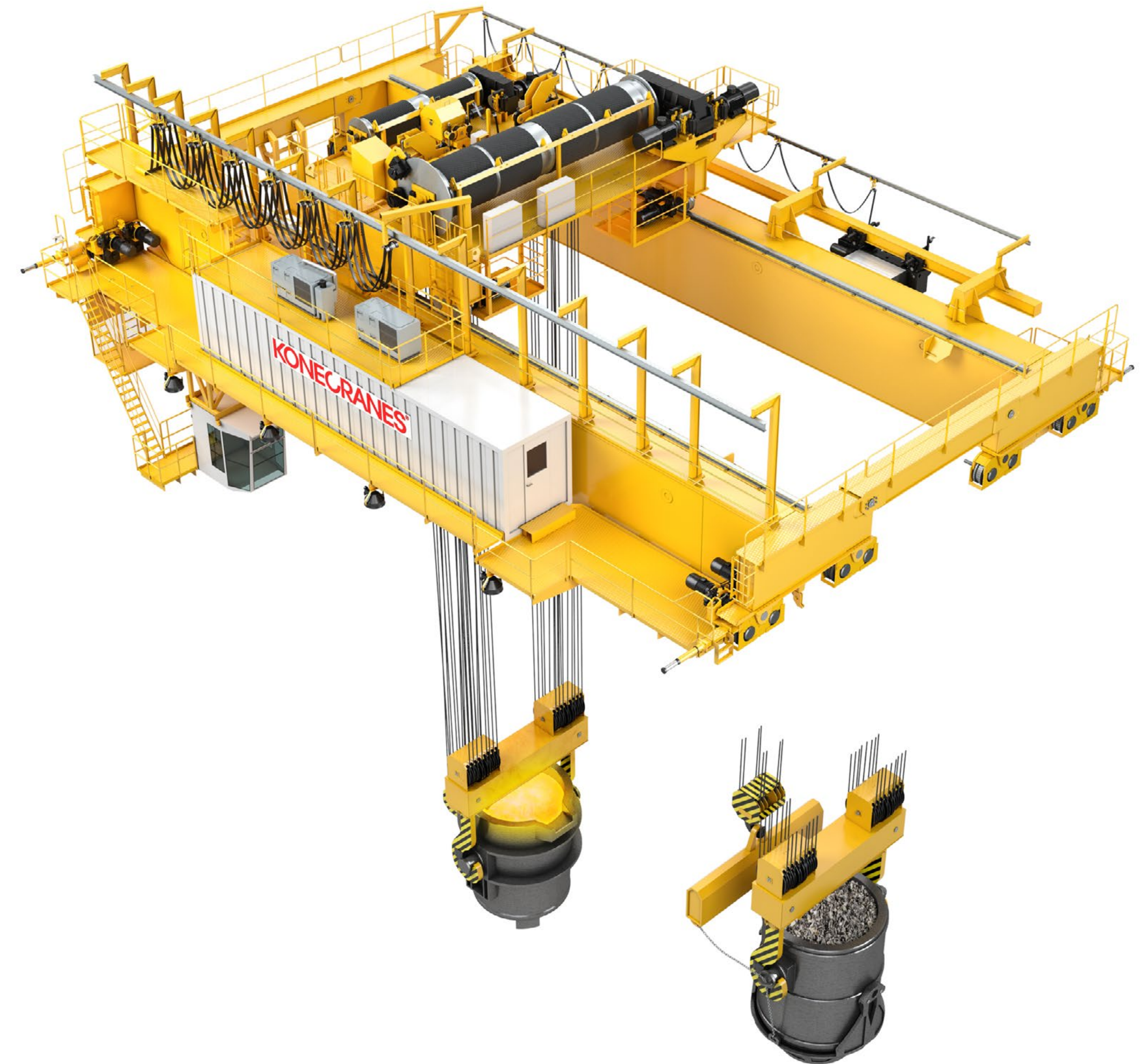

SEE TAILORED
CRANES IN ACTION



LEARN MORE ABOUT SMART FEATURES



INTELLIGENT LIFTING WITH SMART FEATURES

Konecranes Smart Features represent some of the most advanced crane technologies on the market today. They can be added to your new Konecranes cranes, and they can also be installed on your existing Konecranes lifting equipment.

MORE FLEXIBLE LIFTING

Would you like to change the speed of your lift, control load sway, prevent your ropes from going slack, synchronize with other hoists or position your load more accurately?

You can do all of this and more with a choice of Smart Features that allow you to lift flexibly, according to your needs.

Smart Features are available for the following industrial cranes:

CXT CRANES



UNITON CRANES













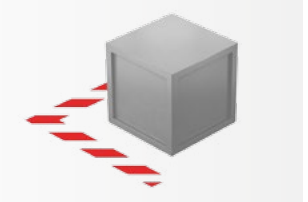





SMARTON CRANES

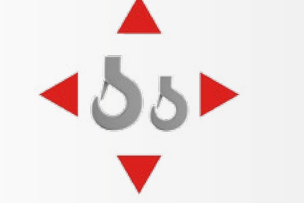

- SMART FEATURES OFFER MANY ADVANTAGES:**
- SAFER OPERATIONS
 - FASTER WORK CYCLE
 - BETTER LOAD HANDLING
 - LONGER CRANE LIFETIME

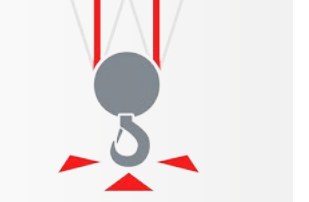

LEARN HOW YOU CAN BENEFIT FROM EACH SMART FEATURE

 WORKING LIMITS	 TARGET POSITIONING	 MICROSPEED	
 INCHING	 ASR & ESR	 ACTIVE SWAY CONTROL	 SLACK ROPE PREVENTION
 SWAY CONTROL	 HOISTING SYNCHRONIZATION	 SHOCK LOAD PREVENTION	 PROTECTED AREAS
 LOAD FLOATING	 ASSISTED LOAD TURNING	 HOOK CENTERING	 FOLLOW ME
 END POSITIONING	 SNAG PREVENTION	WATCH THE VIDEO ▶	

WE UNDERSTAND YOUR PRODUCTION

We have decades of experience working in close cooperation with our customers in various industries. We serve a broad range of customers, including general manufacturing, process industries and terminals. Regardless of your lifting needs, we are committed to providing you with lifting equipment and service that increase the safety and productivity of your business.

READ MORE ABOUT OUR EQUIPMENT RANGE AND SERVICES FOR EACH INDUSTRY:

AUTOMOTIVE

METALS PRODUCTION

PAPER AND FOREST

POWER

**GENERAL
MANUFACTURING**

**WASTE TO ENERGY
AND BIOMASS**



CORE OF
LIFTING



CORPORATE
RESPONSIBILITY

WE MEET OUR CUSTOMERS' NEEDS

We help to improve performance and efficiency in these industries and many more around the world, from small workshops to large mills and anything between.

AUTOMOTIVE

Jaguar Land Rover,
Wolverhampton, UK

METALS PRODUCTION

Bluescope Steel Limited,
Wingfield, Australia

PAPER AND FOREST

Stora Enso Packaging,
Imatra, Finland

POWER

Alstom Power Systems
GmbH, Mannheim, Germany

GENERAL MANUFACTURING

Abloy Oy, Joensuu, Finland

WASTE TO ENERGY AND BIOMASS

The city of Quebec, Canada



CORE OF
LIFTING



CORPORATE
RESPONSIBILITY

KEEPING YOUR EQUIPMENT SAFE AND PRODUCTIVE

Around the corner and around the globe, we have one of the largest and most extensive service networks in the industry. Lifecycle Care is our comprehensive and systematic approach to maintenance and is supported by world-class tools and processes.

An active preventive maintenance program is crucial to improving safety and productivity. We can create a maintenance plan based on your equipment, application and duty cycle.



CORE OF LIFTING



CORPORATE RESPONSIBILITY





SAFETY IS EVERYTHING

We provide specialized maintenance service and spare parts from a single piece of equipment to entire operations. Our objective is to improve the safety and productivity of our customers' operation.

OUR APPROACH TO CRANE MAINTENANCE

Lifecycle Care results in highest lifecycle value –maximizing the productivity of uptime and minimizing the cost of downtime.

[WATCH THE VIDEO ▶](#)

SERVICE PROGRAMS

Our service programs range from on-demand services to complete maintenance and material handling outsourcing.

[READ MORE](#)

SPARE PARTS

When it comes to parts and service, it doesn't matter who made your crane. With 24/7 ordering and fast delivery, we can provide the parts you need when you need them.

[READ MORE](#)





Contact Konecranes today to learn more about how our Industrial Cranes can help you meet your field maintenance and lifting needs.

[CONTACT US](#)

FOLLOW US

[in LINKEDIN](#) [TWITTER](#) [YOUTUBE](#) [FEED](#)

Konecranes is a world-leading group of Lifting Businesses™ offering lifting equipment and services that improve productivity in a wide variety of industries. The company is listed on Nasdaq Helsinki Ltd (symbol: KCR1V). With approximately 12,000 employees at 600 locations in nearly 50 countries we have the resources, technology and determination to deliver on the promise of Lifting Businesses™.

© 2016 Konecranes. All rights reserved. 'Konecranes', 'Lifting Businesses', 'C' and 'TRUCONNECT' are either registered trademarks or trademarks of Konecranes Global Corporation.

